

Cuisinart®

INSTRUCTION
BOOKLET



12-Cup Classic Percolator

PRC-12 Series

CONTENTS

Important Safeguards	2
Unpacking Instructions	3
Introduction	3
Features and Benefits	4
Using the Percolator	5
Cleaning and Maintenance	6
Warranty	7

IMPORTANT SAFEGUARDS

When using an electrical appliance, basic safety precautions should always be followed, including the following:

1. **READ ALL INSTRUCTIONS.**
2. Do not touch hot surfaces. Use handles and knobs.
3. To protect against fire, electrical shock, and injury to persons, **DO NOT IMMERSE CORD, plug, or unit in water or other liquids.**
4. Close supervision is necessary when any appliance is used by or near children.
5. Unplug from outlet when not in use and before cleaning. Allow to cool before putting on or taking off parts, and before cleaning appliance.
6. Do not operate any appliance with a damaged cord or plug or after the appliance malfunctions or has been damaged in any manner. Return appliance to the nearest Cuisinart Authorized Service Facility for examination, repair, or adjustment.
7. The use of accessory attachments not recommended by Cuisinart may result in fire, electrical shock, or injury to persons.
8. Do not use outdoors.
9. Do not let power cord hang over edge of table or counter, or touch hot surfaces.
10. Do not place on or near a hot gas or electric burner, or in a heated oven.
11. Always fill the percolator first, and then plug cord into wall outlet. To disconnect, remove plug from wall outlet before removing plug from unit.

12. Do not operate without adding the minimum amount (16 oz.) of water first.
13. Do not use appliance for other than intended use.
14. **Scalding may occur if the cover is removed during the brewing cycle.**
15. Be sure cover is secure before serving any beverages.
16. **WARNING: TO REDUCE THE RISK OF FIRE OR ELECTRIC SHOCK, DO NOT REMOVE THE BASE PANEL. NO USER SERVICEABLE PARTS ARE INSIDE. REPAIR SHOULD BE DONE ONLY BY AUTHORIZED PERSONNEL.**

SAVE THESE INSTRUCTIONS FOR HOUSEHOLD USE ONLY

SPECIAL CORD SET INSTRUCTIONS

A short power-supply cord on the stay-cool base is provided to reduce the risks resulting from becoming entangled in or tripping over a longer cord.

Longer extension cords are available and may be used if care is exercised in their use.

If a long extension cord is used, the marked electrical rating of the extension cord should be at least as great as the electrical rating of the appliance, and the longer cord should be arranged so that it will not drape over the countertop or tabletop where it can be pulled on by children or animals or tripped over.

NOTICE: This appliance is of the grounded type; the extension cord should be a grounded type 3-wire cord. If the plug does not fit contact a qualified electrician. Do not modify the plug in any way.

UNPACKING INSTRUCTIONS

Place your Cuisinart® 12-Cup Classic Percolator in its gift box on top of a sturdy surface to unpack. Open the gift box, the top flaps, and the top of the corrugated insert. Remove the cover and the pump tube, then remove the top insert. Lift the percolator from the box, then remove the bottom insert from the percolator bottom. Check that all printed materials are removed from the gift box. Dispose of all packaging material, including bags, properly.

Keep all plastic bags away from children.

Before using for the first time: Wash all parts according to the Cleaning and Maintenance section of this booklet to remove any dust or residue.

INTRODUCTION

Congratulations! You've just purchased a little piece of nostalgia that makes a great cup of coffee. Cuisinart's percolator lets you make 4 to 12 cups of rich, flavorful brewed coffee in just minutes. The classic stainless steel design helps keep coffee warm, and the stay-cool bottom means you can set it down almost anywhere without a worry.

So, prepare a pot, listen to the friendly "perk", and watch it brew right through the transparent knob on the cover. When the ready light comes on, sit down, relax, and enjoy a cup of coffee.

Like all Cuisinart® appliances, this product was designed to give you years of satisfaction and is backed by a three-year limited warranty.

USING THE PERCOLATOR

1. Before using for the first time, thoroughly wash all parts of the percolator. (See the Cleaning and Maintenance Instructions section of this booklet.)
2. Remove cover, basket, lid and pump tube with spring. Using the measurement markings (located inside the body) fill the percolator with the desired amount of water. For best results be sure to use cold water when filling the percolator. When preparing 4 cups, use the small circular marking as the 4-cup level mark.

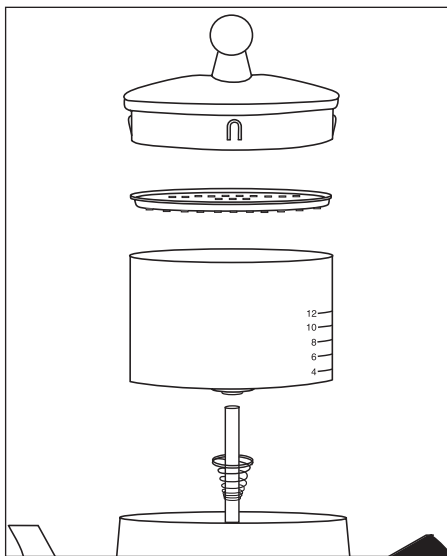

3. Run cold water over the coffee basket. Place basket on top of pump tube. Add desired amount of coffee according to level markings on basket. To help keep small coffee grounds from sifting through the holes in the basket, be certain to use a grind designed for percolator coffee, or use a coarse grind. Finer grinds may sift through the holes.
4. Place basket and pump tube assembly into percolator so bottom of tube fits into well. Place basket cover on top of basket and push cover onto top of percolator.
5. Plug base into standard household 120 volt AC wall outlet. Brewing begins within seconds, and continues at a rate of approximately one cup per minute.

The following chart serves as a guide for preparing various brew strengths. Amounts can be varied to suit personal taste and particular coffees.

Brew Strength of Coffee/ Number of Coffee Measures*			
# Cups	Mild	Medium	Strong
12	12	16	20
10	10	14	18
8	8	12	16
6	6	8	12
4	4	6	8

*1 coffee measure = 1 level tablespoon

6. Once brewing cycle is complete, indicator light will illuminate to signal your coffee is ready.
- Warning:** Be certain the percolating process has stopped completely before removing cover.
7. Once brewing has been completed, remove the cover carefully and using a mitt or potholder, remove the basket and pump tube.
Caution: do not touch the stainless steel parts of the percolator, as they will be hot. Replace cover so it snaps into place. You are now ready to enjoy a flavorful cup of coffee.
 8. Remove plug from percolator for easy serving. Replace plug to keep coffee hot.

CLEANING AND MAINTENANCE

Always remove the plug from the electrical outlet before attempting to clean the percolator.

The percolator cover, basket, lid, and pump tube (with spring) can all be placed in the upper rack of a dishwasher or washed in warm soapy water and rinsed thoroughly.

Never wash percolator body or power cord in dishwasher.

Never immerse the percolator body in water or other liquid. To clean, simply wipe with a clean, damp cloth and dry before storing.

Do not use scouring agents or harsh cleaners on any part of the percolator.

Note: Washer at bottom of pump tube must move freely. Should coffee grounds become trapped near the washer, loosen with a toothpick, then run under tap water to clean.

Storage: Percolator should be stored with cover off.

DECALCIFICATION

Decalcification refers to removing the calcium deposits that form on the metal parts of the percolator over time.

For best performance from your percolator, decalcify the unit from time to time. The frequency depends upon the hardness of your tap water and how often you use the percolator. Decalcification will clean the interior of the unit.

To decalcify, use cream of tartar, found in the spice section of your grocery store, and water. Put 2 tablespoons of cream of tartar into the coffee basket, and fill the percolator with 6 cups of water. Be sure that all parts are in place, and make sure that the lid is securely on. Plug the power cord connector into the cord insert and plug the unit into an electrical outlet. Let the unit run through its normal cycle. Once complete, discard the cream of tartar and water solution.

Run one cycle of fresh, cold water (without cream of tartar) through the unit at the completion of decalcification before using the unit to brew coffee.

WARRANTY

Cuisinart® 12-Cup Classic Percolator

THREE-YEAR LIMITED WARRANTY

This limited warranty is available to consumers only. You are a consumer if you own a Cuisinart® 12-Cup Classic Percolator which was purchased at retail for personal, family or household use. Except as otherwise required under applicable state law, this warranty is not available to retailers or other commercial purchasers or owners.

We warrant that your Cuisinart® 12-Cup Classic Percolator will be free of defects in materials and workmanship under normal home use for three years from the original date of purchase.

We suggest you complete and return the enclosed product registration card promptly to facilitate verification of the date of original purchase. However, return of the product registration card does not eliminate the need for the consumer to maintain the original proof of purchase in order to obtain the warranty benefits. In the event that you do not have proof of purchase date, the purchase date for purposes of this warranty will be the date of manufacture. If your toaster should prove to be defective within the warranty period, we will repair or replace it at our option, without charge to you. To obtain warranty service, simply send the defective product to:

Cuisinart, 150 Milford Rd.
E. Windsor, NJ 08520
or call our Consumer Service Center
toll-free at 1-800-726-0190.

To facilitate the speed and accuracy of your return, please also enclose \$7.00 for shipping and handling of the product. **CA residents need only provide proof of purchase and should call 1-800-726-0190 for shipping instructions.** Please be sure to include a return address, description of the product defect, product serial number and any other information pertinent to the product's return. Please pay by check or money order.

NOTE: For added protection and secure handling of any Cuisinart® product that is being returned, we recommend you use a traceable, insured delivery service. Cuisinart cannot be held responsible for in-transit damage or for packages that are not delivered to us. Lost and/or damaged products are not covered under warranty.

Your Cuisinart® 12-Cup Classic Percolator has been manufactured to the strictest specifications and has been designed for use with authorized Cuisinart® accessories and replacement parts. **This warranty expressly excludes any defects or damages caused by accessories, replacement parts or repair service other than those which have been authorized by Cuisinart. This limited warranty does not cover any damage caused by accident, misuse, shipment or other than ordinary household use.**

This warranty excludes all incidental or consequential damages. Some states do not allow the exclusion or limitation of these damages, so these exclusions may not apply to you. **All applicable implied warranties, including the implied warranty of merchantability and fitness for a particular purpose, given to you by law, are hereby limited in duration to this warranty.**

This warranty gives you specific legal rights and you may have other rights which vary from state to state.

If you have any questions about the safety features of your Cuisinart® 12-Cup Classic Percolator, please call us, toll-free, at 1-800-726-0190.

BEFORE RETURNING YOUR CUISINART PRODUCT

If you are experiencing problems with your Cuisinart product, we suggest that you call our Consumer Service Center at 1-800-726-0190 before returning the product for servicing. Often, our Consumer Service Representatives can help solve the problem without having the product serviced. If servicing is needed, a representative can confirm whether the product is under warranty and direct you to the nearest service location.

***Important: If the nonconforming product is to be serviced by someone other than Cuisinart's Authorized Service Center, please remind the Servicer to call our Consumer Service Center at 1-800-726-0190 to ensure that the problem is properly diagnosed, the product is serviced with the correct parts, and the product is still under warranty.**

CALIFORNIA RESIDENTS ONLY

California law provides that for In-Warranty Service, California residents have the option of returning a nonconforming product (A) to the store where it was purchased or (B) to another retail store which sells Cuisinart products of the same type. The retail store shall then decide to either repair the product, refer the consumer to an independent repair facility, replace the product, or refund the purchase price less the amount directly attributable to the consumer's prior usage of the product. If either of the above two options does not result in the appropriate relief to the consumer, the consumer may then take the product to an independent repair facility if service or repair can be economically accomplished. Cuisinart and not the consumer will be responsible for the reasonable cost of such service, repair, replacement, or refund for nonconforming products under warranty.

California residents may also, according to their preference, return nonconforming products directly to Cuisinart for repair or, if necessary, replacement, by calling our Consumer Service Center toll-free at 1-800-726-0190. Cuisinart will be responsible for the cost of the repair, replacement, and shipping and handling of such nonconforming products under Warranty.

Cuisinart®

SAVOR THE GOOD LIFE®



Coffeemakers



Food Processors



Toasters



Rice Cookers



Cookware



Grills

Cuisinart offers an extensive assortment of top quality products to make life in the kitchen easier than ever. Try some of our other countertop appliances and cookware, and Savor the Good Life®.

www.cuisinart.com

©2005 Cuisinart
Cuisinart® is a registered
trademark of Cuisinart

150 Milford Road
East Windsor, NJ 08520
Printed in China
05CU26239

U IB-6072

Version no.: PRC12 IB-6072

SIZE: 152mm(W) x 203mm(H)
Total Pages : 8pcs

Material:
Cover: 157gsm Matt Artpaper
Inside: 120gsm Gloss Artpaper

Coating: Varnishing in cover

Color:
Cover: 4C + 1C (Black)
Inside: 1C + 1C (Black)

Date: 04/15/05

P. O.: 0504000 (04/00/2005_OP)



新成 分色 製版 公司
Classic Graphic Arts Company

Tel: 2357 0071

Fax: 2357 0318